

Quick Start Guide without duct clamp

The ABF (Air Blown Fibre) tool is used to install Hexatronic Stingray fibres into small duct tubes. Depending on the duct size and fibre size, the fibre can be installed over fairly long distances. The motor pushes the fibre through the tube with the air used to float the fibre in the tube and reduce friction between the fibre and inside of the tube.

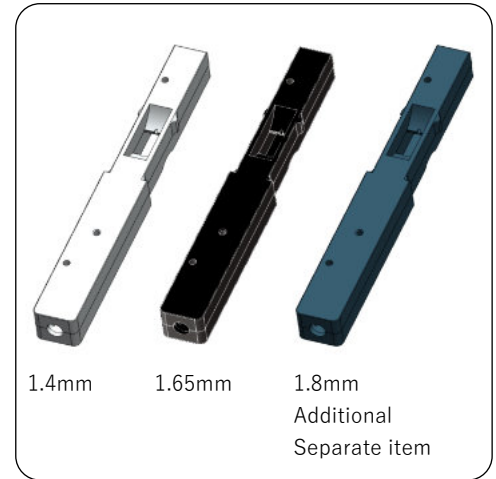

1. Identify the fibre that you need to blow. Check the outside diameter of the cable (refer to the data sheet specification if required).

2. Select the correct fibre guides based on the cable diameter and put them on the tool (See section 4.4 of the user manual).

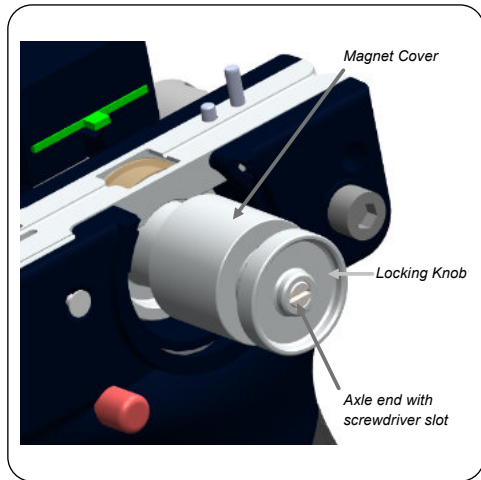

3 Adjust the clutch tension for the fibre type. (See section 4.1 of the user manual).

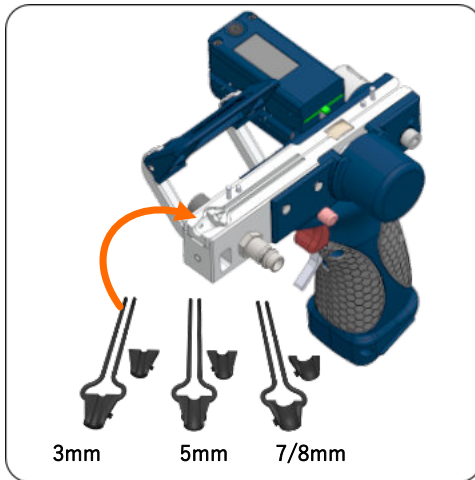

4. Identify the duct size the fibre will be blown into and change both rubber nozzles (upper and lower) to the correct size (see section 4.7 of the user manual).



5. Put a charged battery into the tool.

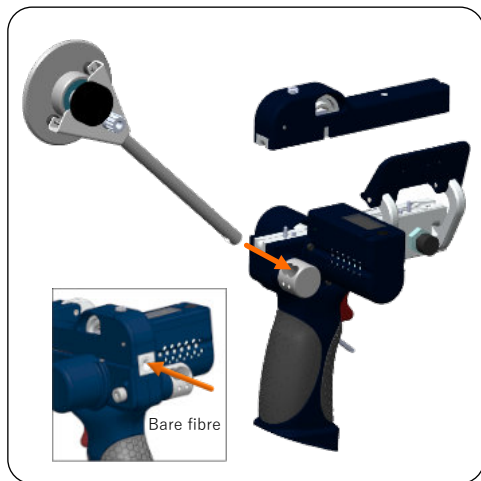

6 Put the reel arm in place according to the reel size (bare fibres can be installed directly through the back of the gun and no reel arm is needed).

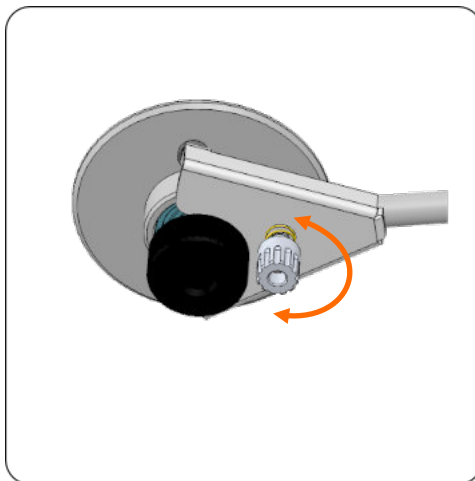

7. Adjust the brake plate tension to have a small amount of braking applied. Loosen first, then adjust to have some friction applied.



8. Mount the ABF tool to the tripod at the work area.

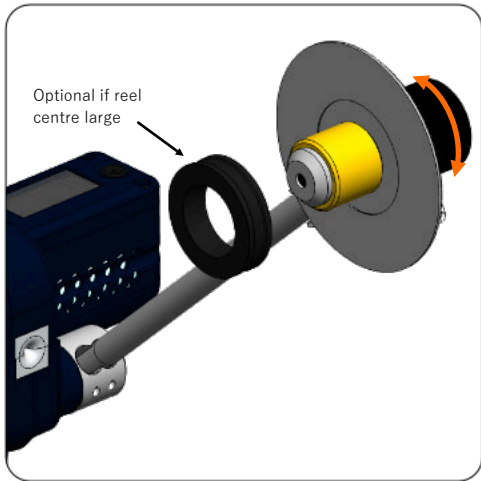

9. Mount the fibre reel. Loosen the knob to reduce the expander (shown yellow). Fit the reel (add black fitting if required). Tighten knob until reel fitting is good.

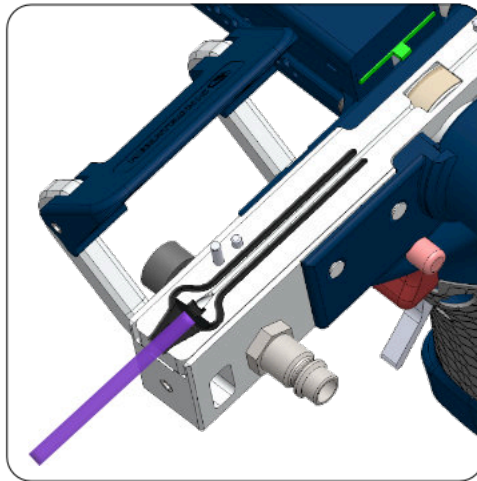

10. Open the clamp, lift the top body and place the duct onto the nozzle, hold whilst closing the clamp. (for pre-connectorized fibre: push the ferrul into the duct before closing the lever).

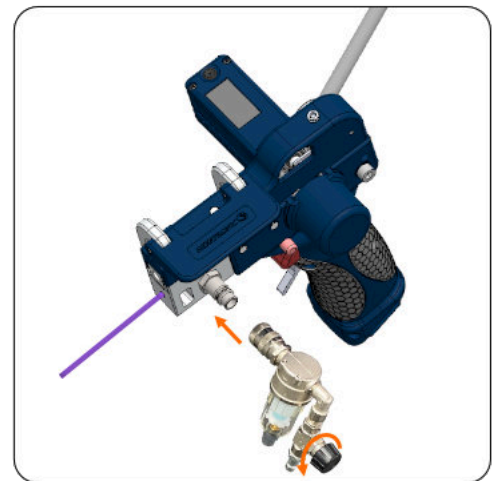

11. Connect the air filter and valve assembly to the tool - open the valve - turn anticlockwise.



12. Purge the air from the compressor & leave the valves open (see compressor operating guide). Connect the air line, first to the ABF tool, then to the compressor.



13. Start the compressor. if using bare fibre from the pan. Feed the fibre into the back of the ABF tool so it comes through a short way and reaches the duct you are blowing the fibre into.



14. Pull the trigger and ensure the fibre is moving freely.



15. The display will show the distance the fibre has travelled and the speed while the fibre is moving.

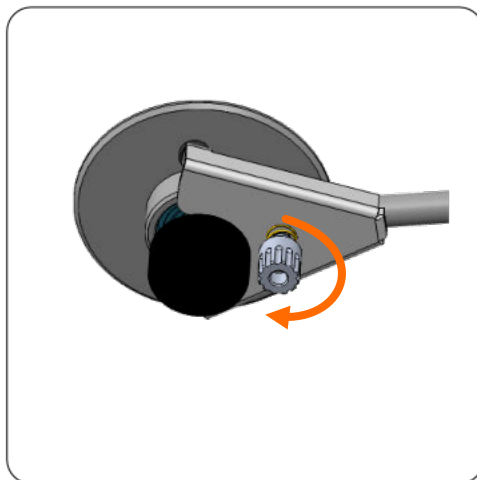

16. If the fibre reel spins when you let go of the trigger - apply a little more pressure to the brake plate.